

Installation for track

1. Use wire stripper (TG-KXQ) to cover the track and divide it into 6 single wires according to wire trough.

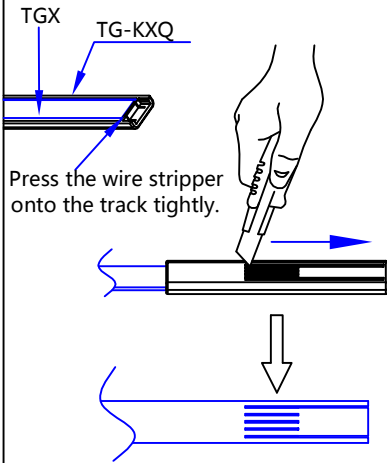

2. Trim the excess portions of the four wires in the middle.

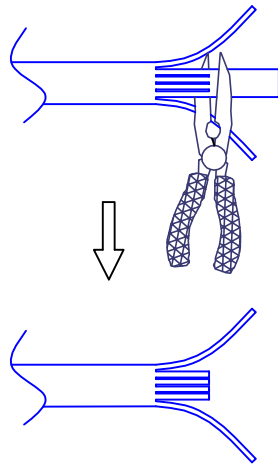

3. Strip off the outer covering of the steel wire rope and copper wires, being careful not to cut the steel wire rope.

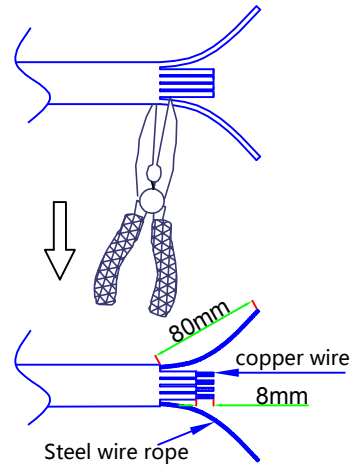

4. Use copper tubing to connect the track wire and the external wire." (as shown on the right)

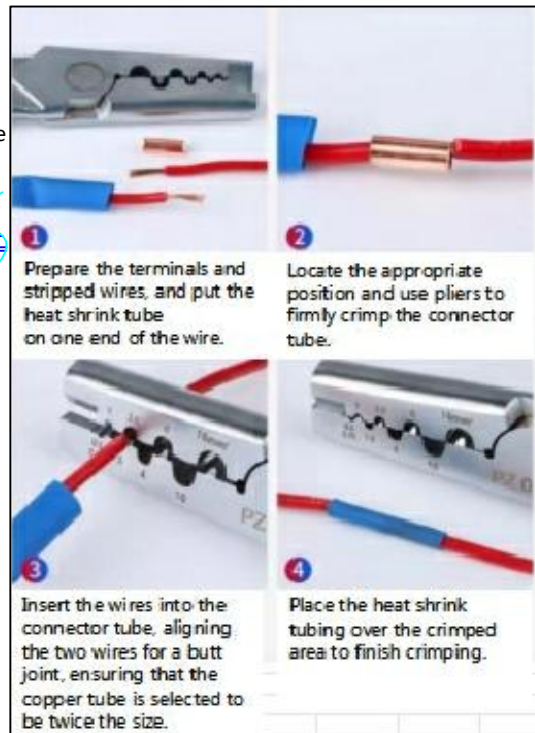
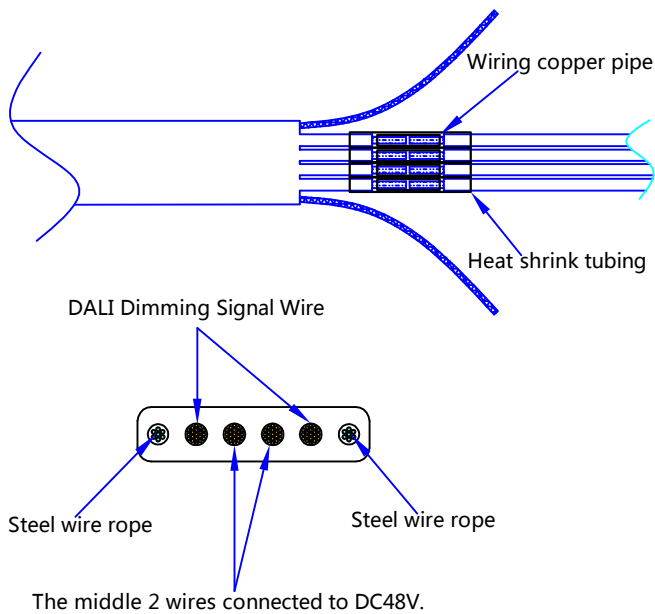

5. Use TF05 and TF06 to clamp the wire rope up and down, be sure to tighten it and tighten the screws.

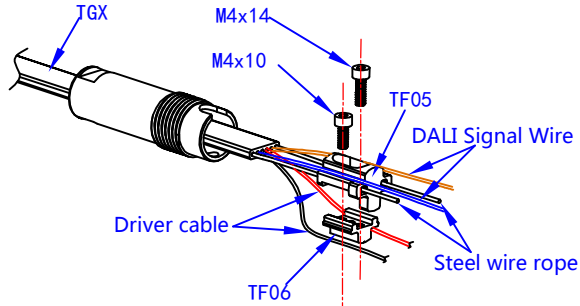

6. Thread the wire through the interior of TF03, rotate TF03, and align it with TF04 for proper coordination.

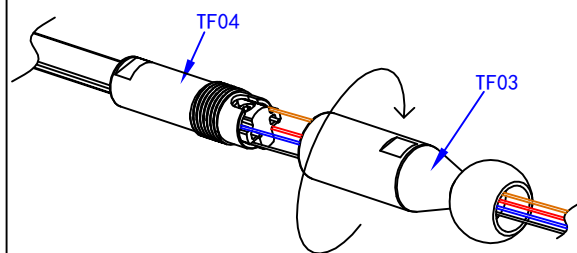

Main components of the Tightener

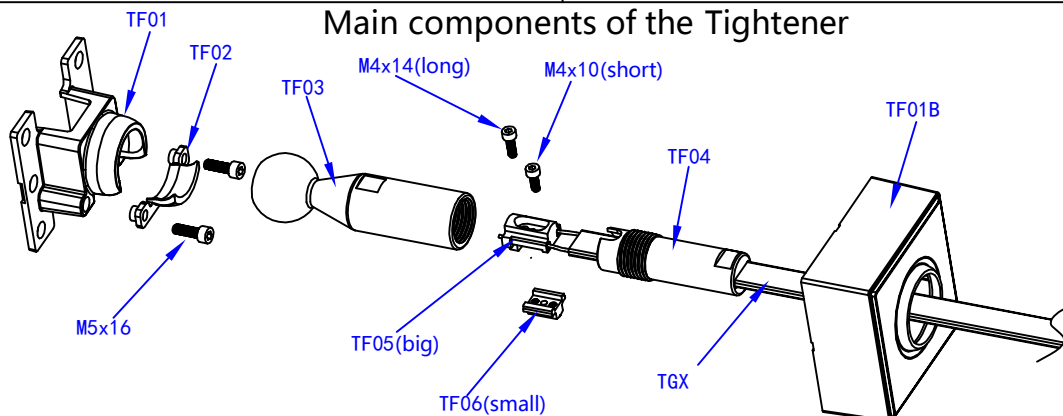

Instruction of wiring side A

A1: Fix the screw, screw hole reference as shown on the right

A2: Fix well the base

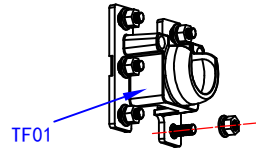
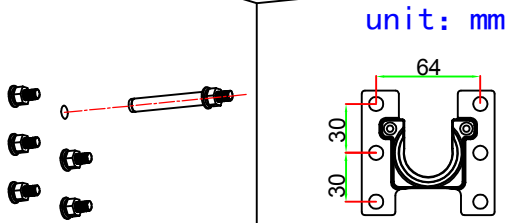

A3: Fix the globular accessory by M5x16 (Screw)

A4: Cover TF01B onto TF02

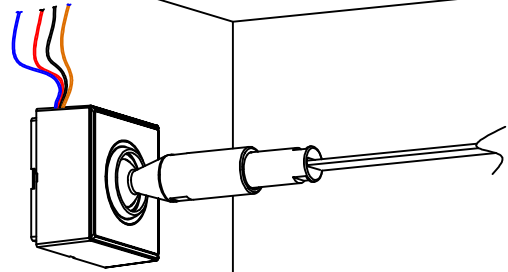
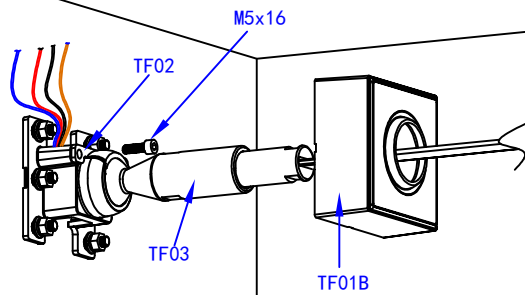

A5: Connect wiring for driver and track

A6: Fix the J-Box on ceiling/wall

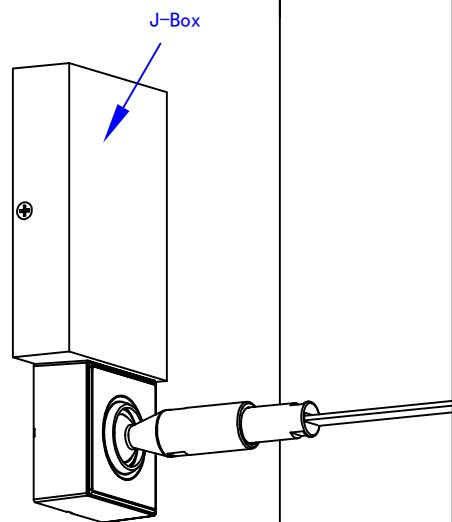
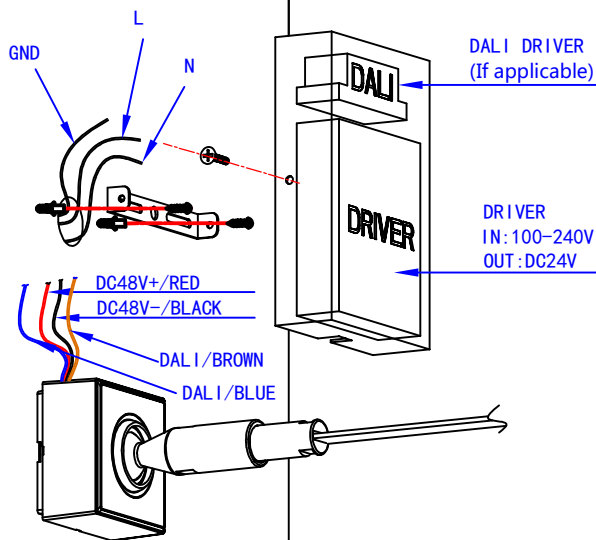

Wiring diagram

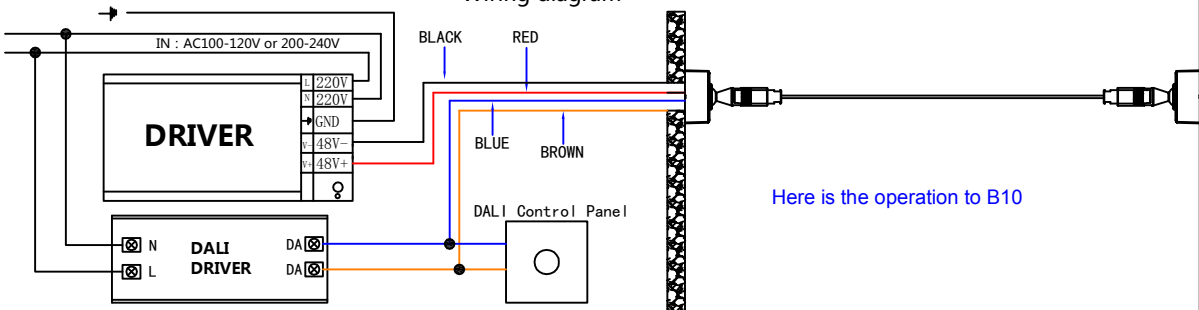

Another side without wiring B

B1: Fix the screw, screw hole reference as shown on the right

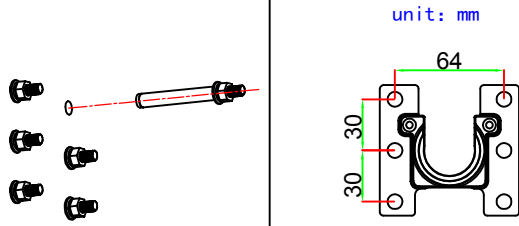

B2: Fix well the base

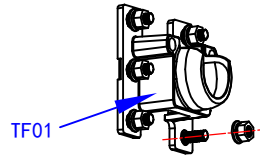

B3: Fix the globular accessory by M5x16(Screw)

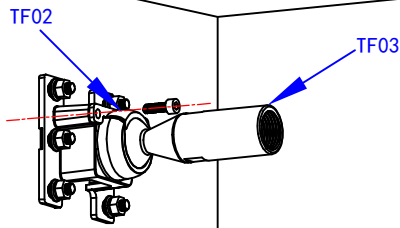

B4: Cut the extra track

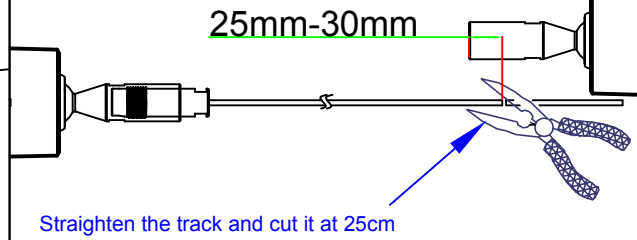

B5: Peel off the plastic cover of the wires and expose the steel wire

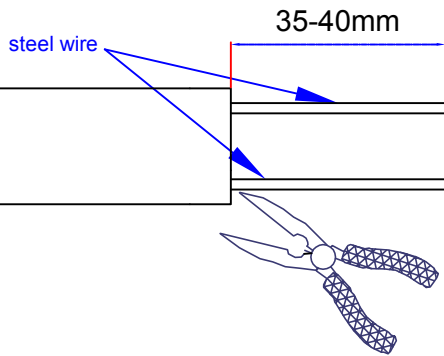

B6: Nip the steel wire

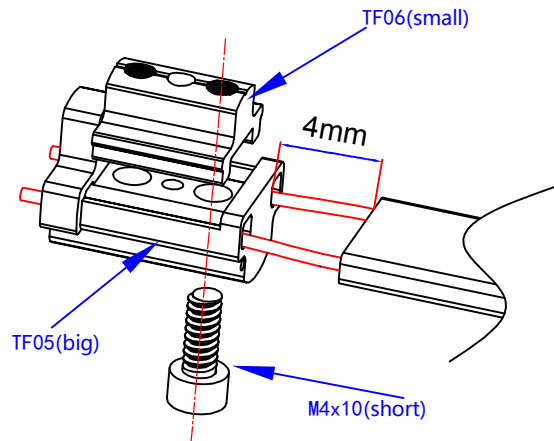

B7: Insert the steel wire into TF04

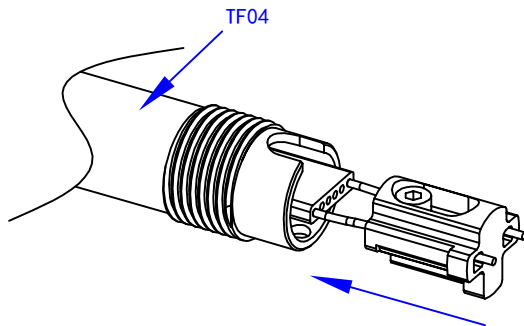

B8: Use M4 x 14 screws fix the wire in TF04

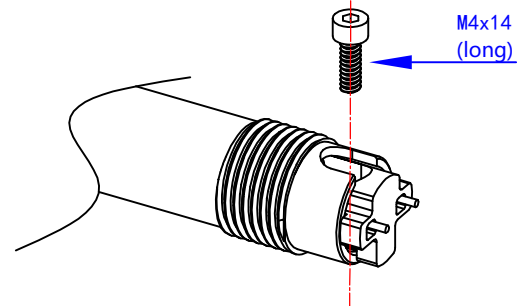

B9: Rotate TF03 into TF04

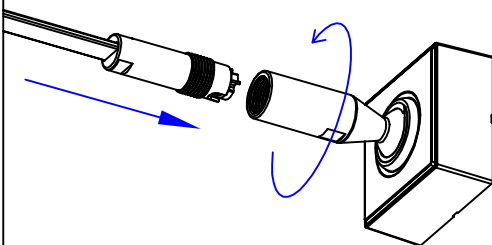

B10: Tighten up

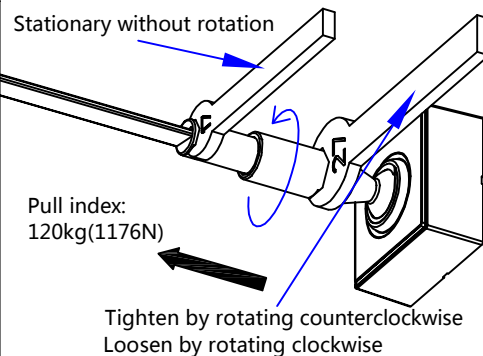

It is recommended to add messenger wire position

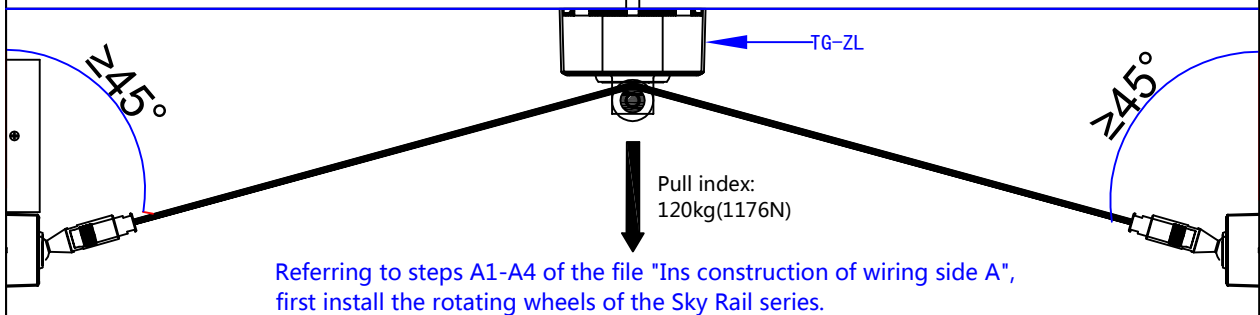
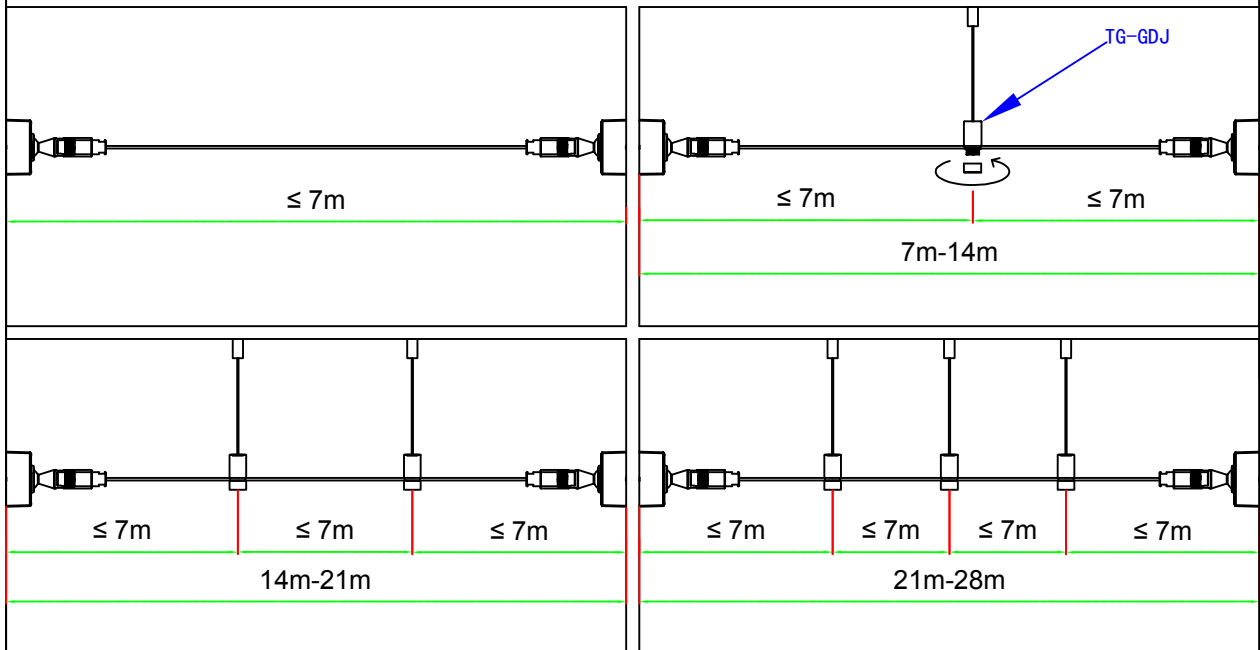
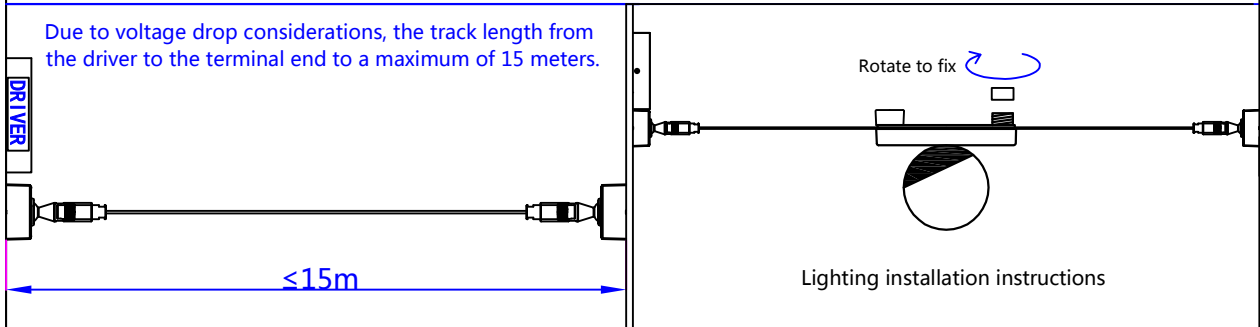
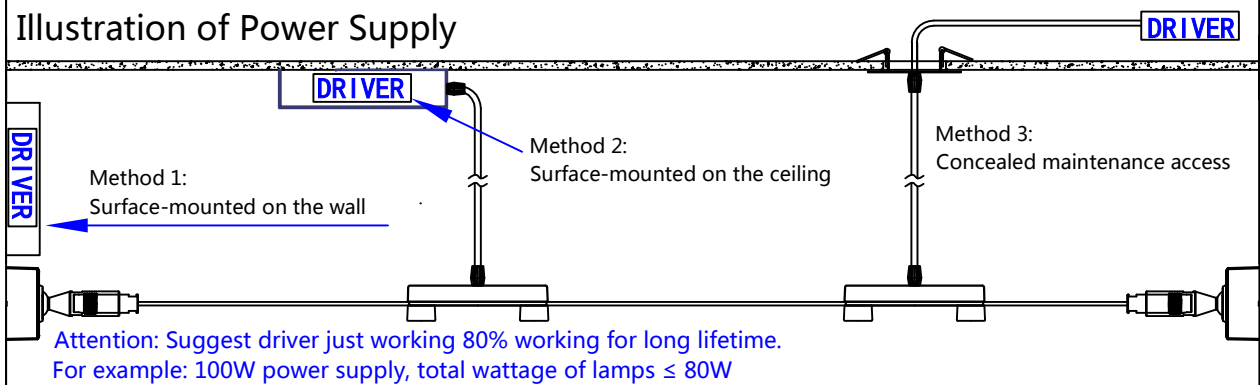

Illustration of Power Supply



Attention:

1. After tightening the track, the tensioner tension reaches 120kg (1176N). Before installation, please ensure that the wall or wallboard can withstand the tensile strength of the track.
2. Step B6, be sure to clamp the steel wire rope to ensure safety.
3. After tightening the steel wire rope, the total weight of the suspended fixture must not exceed 20 kilograms.
4. The light source contained in this luminaire shall only be replaced by the manufacturer or his service agent or a similar qualified person.
5. If the external flexible cable or cord of this luminaire is damaged, it shall be exclusively replaced by the manufacturer or his service agent or a similar qualified person in order to avoid a hazard.
6. The products shall be used with Class III track system certified with standard EN/IEC 60570, IP20, 48Vdc, shall not less than product's wattage.